

# Technical Data Sheet

**Product**

**Model:** AB-4042D

**Description:** Curb-mount style solar powered attic fan constructed from corrosion resistant zincalume alloy steel with heavy-duty powder coated finish, featuring a 14 inch diameter fan blade, remote mounted 40W solar panel with standard flush mounting brackets, 15 foot UV/weather-resistant power cable, stainless steel hardware throughout, thermal switch and fire safety switch included.

**Revision:** 1

**Date:** 2/8/2018

**DCN:** TDS-4042D

TOP VIEW

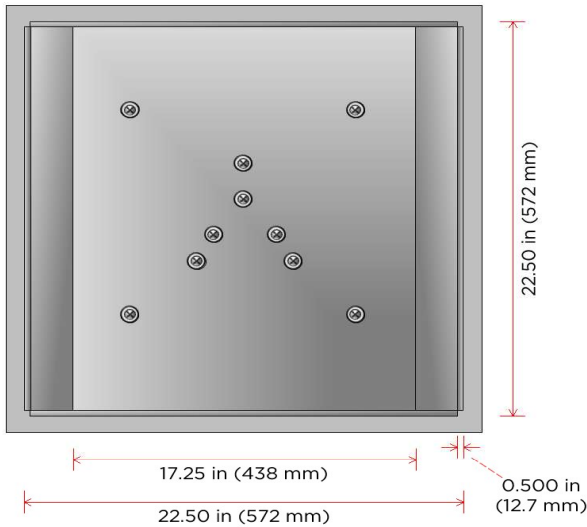

BOTTOM VIEW

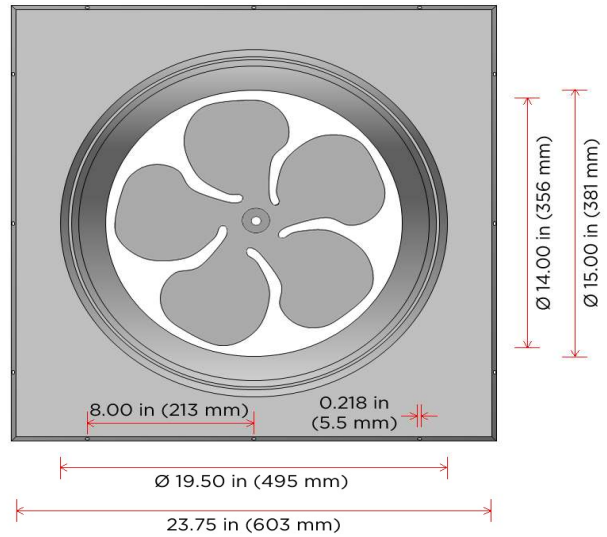

FRONT VIEW

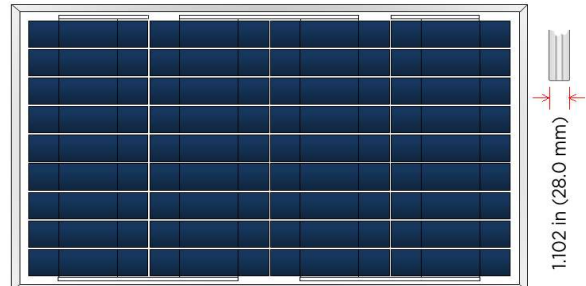
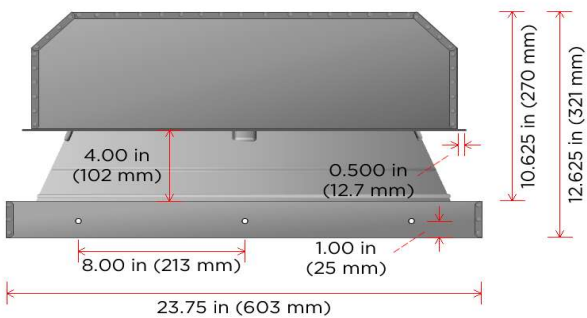

SIDE VIEW

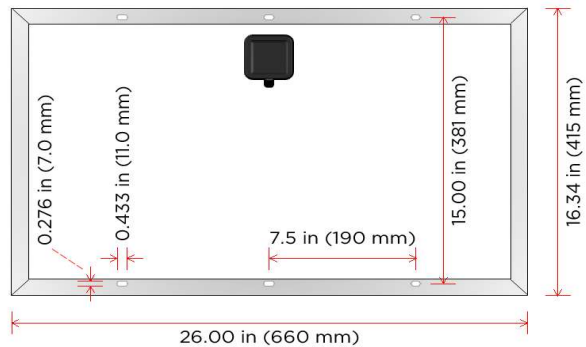
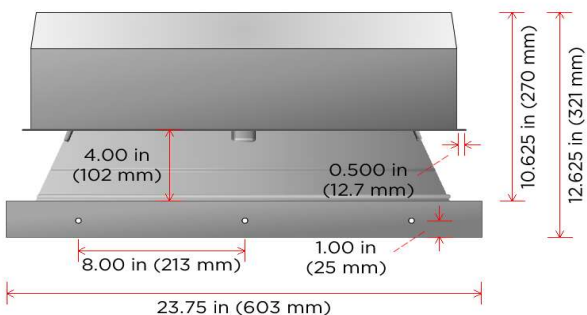

# Technical Data Sheet

## **Materials**

<b>Hood &amp; Base:</b>	22 GA (0.027 in; 0.686 mm) Zincalume/Galvalume AZ50 (ASTM A792)
<b>Support Brackets:</b>	16 GA (0.058 in; 1.473 mm) Galvanized Steel G90 (ASTM A653)
<b>Motor Brackets:</b>	12 GA (0.105 in; 2.667 mm) 304 Stainless Steel (ASTM A666)
<b>Wildlife Screen:</b>	23 GA (0.028 in; 0.710 mm) 304 Stainless Steel; 0.25 in x 0.25 in welded wire mesh
<b>Hardware &amp; Fasteners:</b>	1/4" 18-8 Stainless Steel
<b>Fan Blade:</b>	16 GA (0.050 in; 1.270 mm) Aluminum AL5052 (ASTM B209); 14 in (356 mm) diameter, 5-wing precision balanced blade
<b>PV Panel:</b>	AL5052 aluminum frame with impact-resistant tempered glass; AL5052 aluminum standard mounting brackets (available with adjustable universal bracket kit)

## **Finish**

<b>Coating Type:</b>	Powder coated baked-on finish using Tiger/Drylac Series 38 Super Durable TGIC Polyester coating
<b>Coating Thickness:</b>	2.5-3.5 mils average (ISO 2360)
<b>Adhesion:</b>	5B minimum (ASTM D3359 method B)
<b>Exposure Performance:</b>	Passes natural weathering test (ASTM D2244 & ASTM D523; Florida 5 years exposure) with gloss retention >80% and $\leq \Delta E$ 5.0 color change
<b>Corrosion Resistance:</b>	Passes 2,000 hour acid salt spray resistance testing (ASTM G85) with 1/32 in (1 mm) maximum undercutting
<b>Certifications:</b>	AAMA 2604 compliant
<b>Stock Colors:</b>	jet black, bronze brown, weathered gray, polar white, terra cotta, hickory, shakewood
<b>Custom Colors:</b>	brick red, hawaiian blue, anodized silver, classic green, turquoise, sandstone

## **Electrical**

<b>Motor:</b>	38V variable speed DC motor with sealed bearings; fully enclosed and designed to be intrinsically safe with overload protection
<b>PV Panel:</b>	High efficiency 40 watt panel; monocrystalline solar cells
<b>Internal Wiring:</b>	16/18 AWG wiring throughout unit
<b>Remote Cable:</b>	18 AWG UV/weather resistant power cable (15 feet); available with 14 AWG extended power cable (40 feet)
<b>Termination:</b>	UV/weather resistant quick disconnect plugs
<b>Fan Control:</b>	Includes thermal switch (activates 75°F $\pm$ 7°F, deactivates 55°F $\pm$ 9°F - UL 873 compliant) and fire safety switch (deactivates at 228°F +0°F/-9°F - UL 60691 compliant); Breeze Mate® solar ventilation control system optional

## **Performance**

<b>Max Airflow Rating:</b>	1875 CFM @ 0.0 inH <sub>2</sub> O active under peak sun exposure; 1.31 sqft NFA passive
<b>Noise Level:</b>	< 1 sones (< 30 dB)
<b>Wind Rating:</b>	+115 PSF/-115 PSF (ASTM E330-02); +170 MPH Wind Speed Equivalence*

\* Wind speed equivalence based on 30 foot mean roof height in Exposure B; wind zones 1-3; all roof pitches apply.

<b>Certifications:</b>	Florida Product Approval (FL13339.7 R6)
<b>Warranty:</b>	Residential limited Lifetime Warranty; commercial 25-year limited warranty

## **Weight Load**

<b>Fan Unit:</b>	20 LBS
<b>Remote PV Panel:</b>	7 LBS